

PARRILLAS SILVER

DRAGO



CUERPO

Exterior fabricado en acero inoxidable e interior fabricado en lámina aluminizada.

CHIMENEA

Chimenea perforada fabricada en acero inoxidable

PARRILLAS

Parrillas individuales de 12" x 12" de hierro fundido y recubiertas con pintura de alto calor.

QUEMADORES

Quemadores Tipo Cúpula para fácil limpieza con capacidad de **30,000 BTU/hr**

ZONA DE EMPLATADO

Nuevo diseño de panel superior, 10 cm de ancho para zona de emplatado

PERILLAS

Nuevo diseño en perillas de quemadores

VÁLVULAS

Válvulas de Gas certificadas por CSA

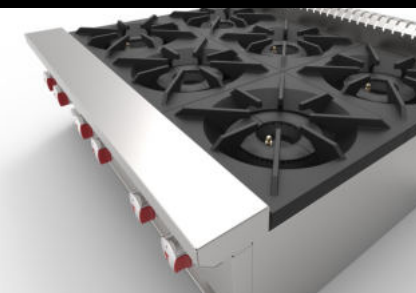
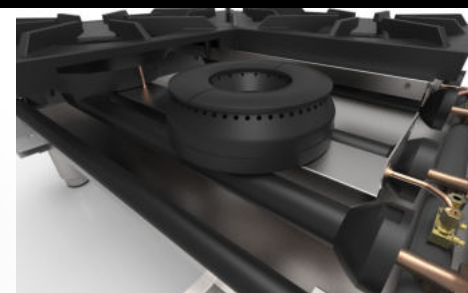
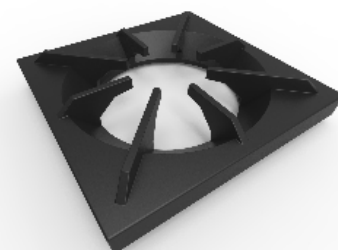
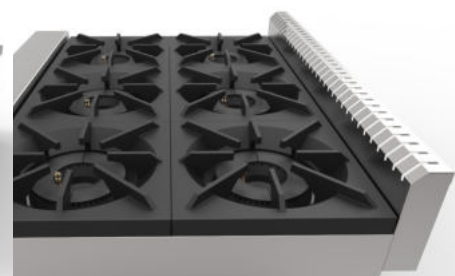
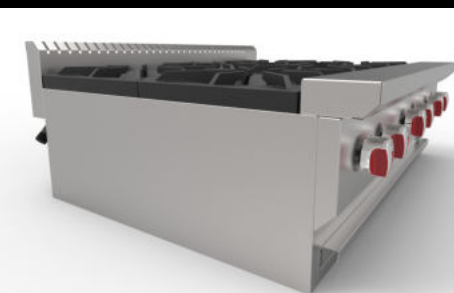

DIMENSIONES GENERALES

VISTA FRONTAL

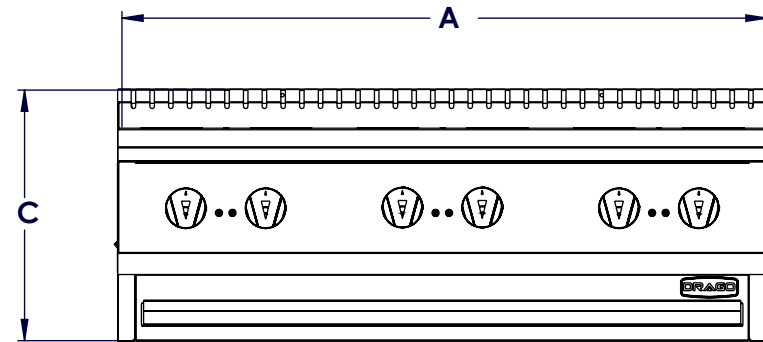

VISTA LATERAL

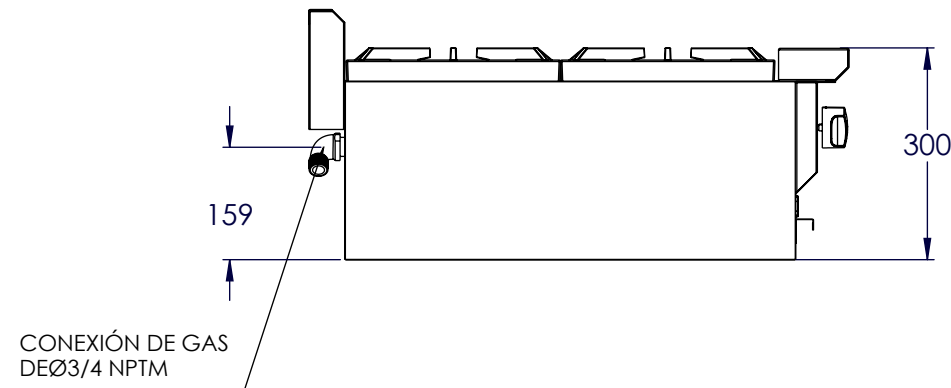

VISTA SUPERIOR

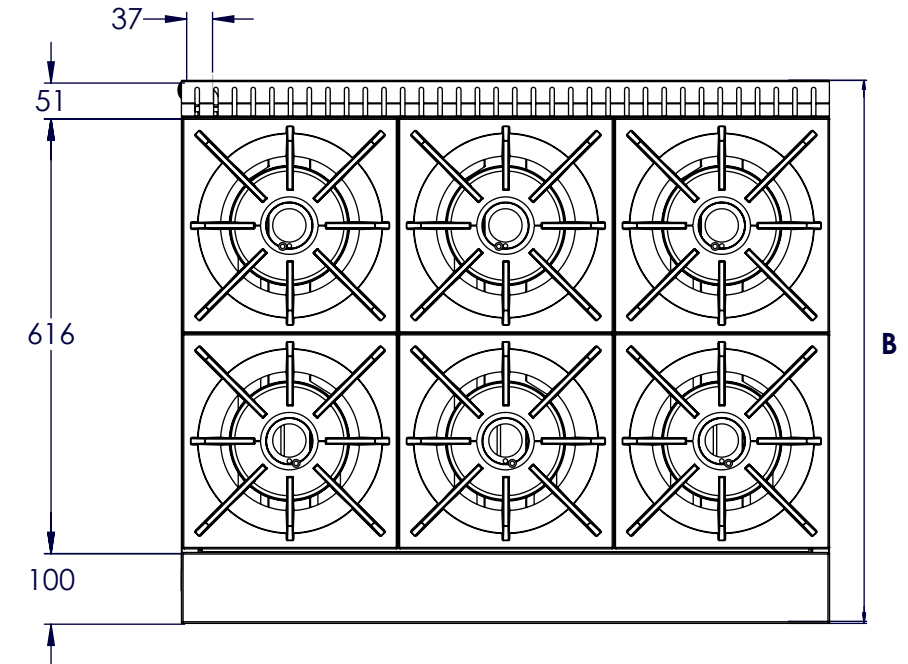

MEDIDAS EN mm

MODELO	A	B	C	PERILLAS	QUEMADORES	BTU's	PESO DEL EQUIPO (Kg)	PESO DEL EQUIPO ENHUACALADO (Kg)
CG-20	305	768	355	2	2	60,000	28	43
CG-40	610	768	355	4	4	120,000	60	80
CG-60	915	768	355	6	6	180,000	75	95

Instalación de conexión al gas:

- Equipos a baja presión
- Presión requerida gas lp 11" Columna de Agua
- Presión requerida gas natural 5" Columna de Agua
- Entrada principal de gas 3/4" NPT Macho.

